

User Instruction Manual

Oxford® Advance

To avoid injury, read user manual prior to use.

Manuel de l'utilisateur

Oxford® Advance

Afin d'éviter tout accident, veuillez lire attentivement la notice avant utilisation.

Manual de Instrucciones

Oxford® Advance

Para evitar posibles daños, lea previamente el manual de usuario.

Benutzerhandbuch

Oxford® Advance

Um Verletzungen zu vermeiden, lesen Sie bitte die Gebrauchsanweisung vor der ersten Benutzung.

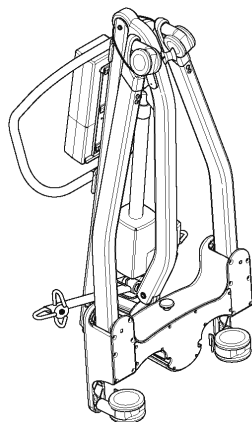
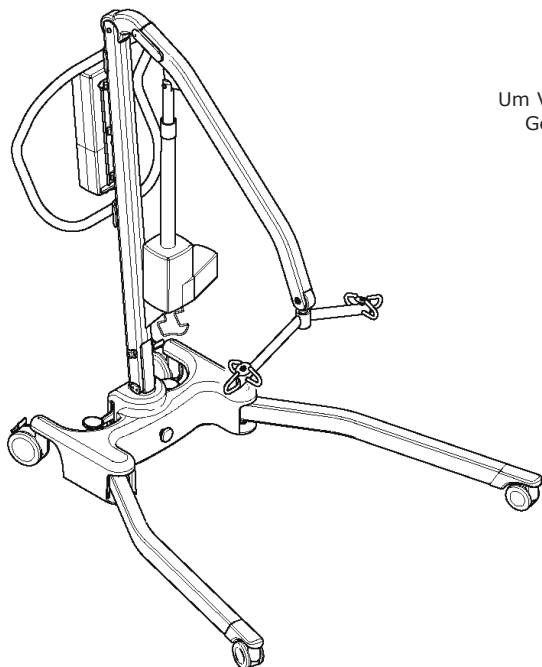

Contents

1. Oxford Advance Patient Lift	3
2. Introduction: The Oxford Advance Patient Lift	4
3. Assembly and Commissioning Instructions	5
4. Disassembly	7
5. Safety Precautions	10
6. Smart Monitor & Handset.....	12
7. Operating Instructions	16
8. Maintenance Schedule.....	20
9. Technical Specifications.....	22
10. Warranty.....	25

1. The Oxford Advance Patient Lift

Oxford Advance lift (ready for use)

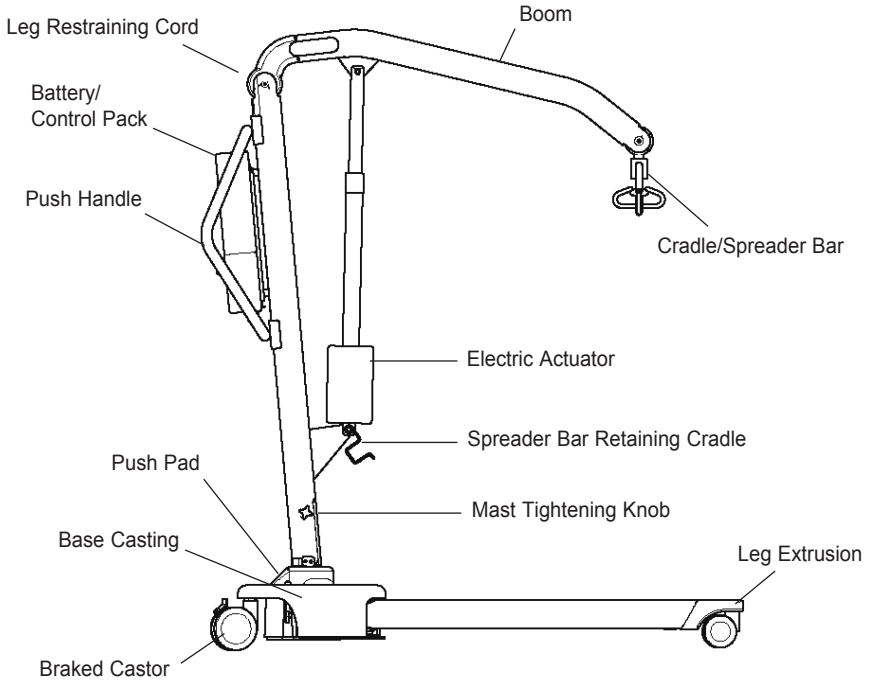

Oxford Advance lift (storage position)

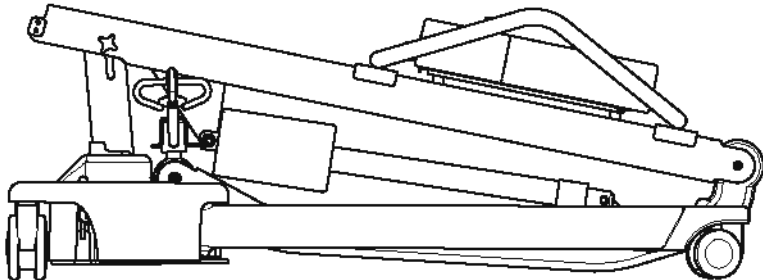

2. Introduction: The Oxford Advance Patient Lift

Each lift is fully assembled, load tested and certified before being packed/shipped.

The packing consists of a strong, purpose built carton and is used for both export and domestic markets to ensure the safe arrival of the lift. A number of documents are supplied in a wallet packed with each lift and should be kept safely for future reference.

- TEST CERTIFICATE
- DEALER GUARANTEE CARD
- USER MANUAL
- CUSTOMER SATISFACTION CARD

The TEST CERTIFICATE is an important document and should be kept for reference purposes. To properly maintain your lift please refer to the maintenance schedule included in this document. If you are at all unsure what your country's servicing requirements are, please check with your dealer and/or a local government agency.

The CE mark: The Oxford Advance carries the CE mark and complies with the following EC directives:



- Medical Device Directive (93/42/EEC)
- EMC Directive (89/336/EEC)
- Low Voltage Directive (73/23/EEC)

Statement of Intended Use

The intended use of this lifting device is for the safe lifting and transfer of an individual from one resting surface to another (such as a bed to a wheelchair). Joerns Healthcare recommends that the transfer of a patient is fully risk assessed and conducted safely over a short distance only.

The Oxford Advance is suitable for patients in the SITTING, SITTING/RECUMBENT and RECUMBENT positions.

The Oxford Advance is designed to support and promote safe patient handling and transfer for both the patient and carer. It can be folded without the use of tools enabling it to be easily stored in environments where space is limited. The Oxford Advance can also be separated into two sections to facilitate onward transportation in a vehicle with a suitably sized boot.

The Oxford Advance patient lift incorporates a 6-point spreader bar and is designed to be used in conjunction with the Oxford range of slings. The examples of slings suitable for use with this device are listed as follows:

- Oxford Quickfit
- Oxford Full Back
- Oxford Quickfit Deluxe
- Oxford Long Seat
- Oxford Access sling
- Oxford Silkfit

Expected Service Life

Oxford Professional lifts are designed and tested for a minimum service life of ten (10) years, subject to the use and maintenance procedures stated in this manual. Use, other than in accordance with these instructions, may compromise service life.

3. Assembly and Commissioning Instructions

Carton Contents

Place the carton in a clear working area and open carefully. The carton contains:

- OXFORD ADVANCE
- WALLET CONTAINING DOCUMENTS
- HAND CONTROL
- BATTERY PACK
- BATTERY CHARGING LEAD

SAFETY NOTE: The Oxford Advance is heavy and will need to be lifted with care. You may need assistance to lift the Oxford Advance from the carton.

Assembly Instructions

1. Remove all the parts from the carton and place on the floor, taking care to protect the finish from damage.

Lift the Advance carefully from the carton. Stand the lift in the upright position (in a triangular stance).

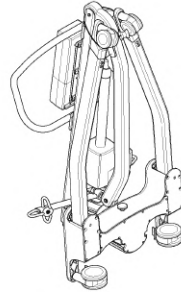
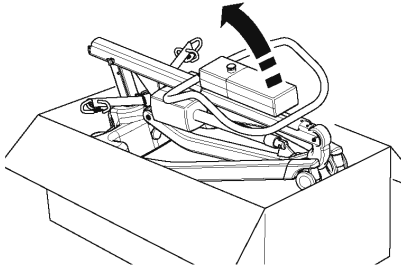

2. Release the leg and mast assembly by unfastening the restraining strap from the wheels. This strap will retract neatly into the top of the mast section.

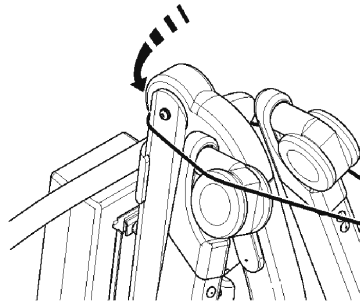
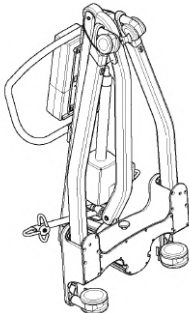

3. Lay the Advance flat on the floor (ensure rear castors are securely locked).

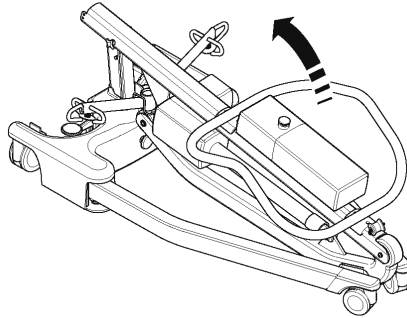

4. Lift the mast assembly upright (using the top of the push handle), and drop the mast into the slot, aligning the mast engagement decals (1), tighten mast lock knobs (2), release braked castors (3).

SAFETY NOTE: Avoid trapping fingers. Keep fingers away from the end of the mast when inserting into the mast slot. Ensure the mast is fully engaged before tightening the mast locking device.

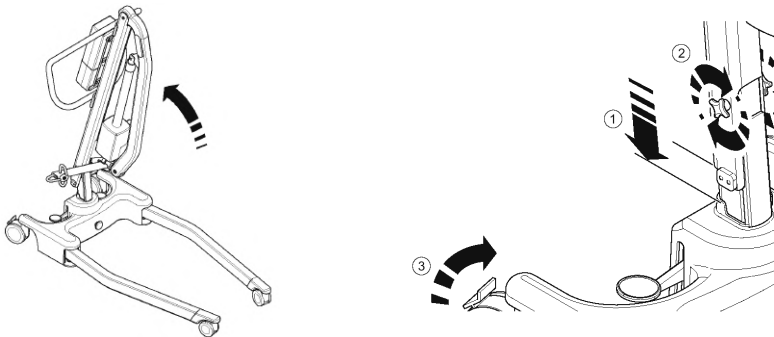

5. Open legs fully. ENSURE leg-locking knob inserts flush against the base casting and the legs will no longer move freely. The legs will then only operate by the use of the foot pedal mechanism located at the rear of the base.

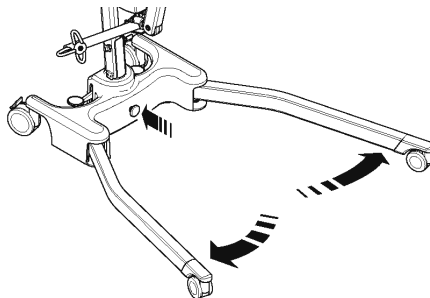

6. Release spreader bar from retaining cradle, and the lift is ready for operation.

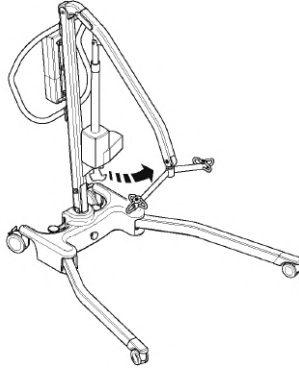

4. Disassembly

1. Lower the mast to the lowest possible position, then insert spreader bar into retaining cradle.

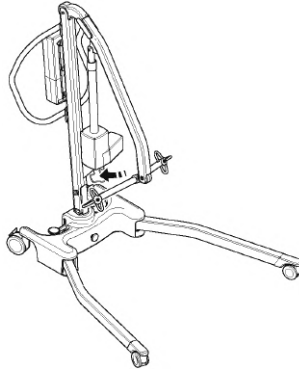

2. Release leg-locking device (pulling it away from the cast base), close legs tightly together.

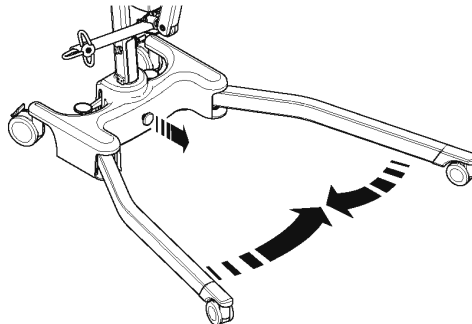

3. Loosen mast locking device (2 - not fully) lift the mast and boom assembly (3), and fold carefully toward the legs. Use the push handle to assist this motion.

NOTE: If you wish to separate the mast and boom completely from the base and legs, undo the mast locking device fully (remove) and lift the mast and boom completely free from the base. Be careful not to lose the mast lock device's knob and location spindle.

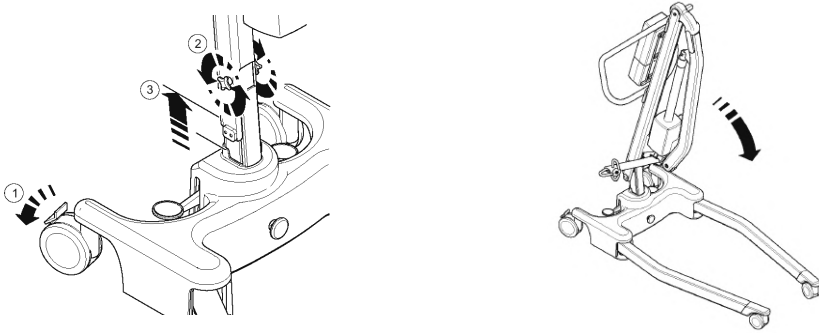

4. Lift the folded Advance upright (using the legs and push handle as a guide) being careful that the mast and boom stay together as you tilt upright.

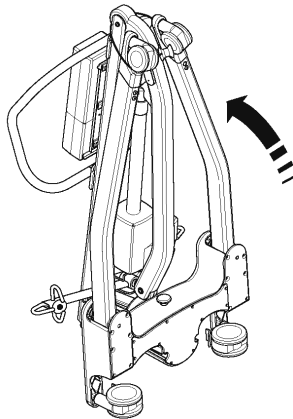

5. Pull the restraining strap sharply upwards and extend over the wheels. (This will keep the legs, mast and boom neatly together during transit and storage).

NOTE: Care should be exercised when folding/unfolding an Advance as there is a possible danger of pinching the fingers etc. Please follow the instructions carefully and ask for assistance if you are unsure of the correct procedure.

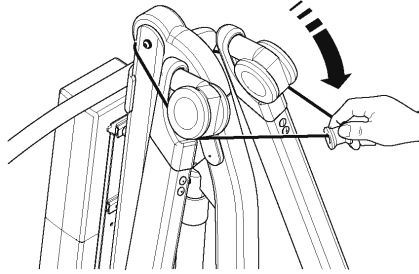

ALWAYS CHECK THE FOLLOWING BEFORE OPERATION:

- The legs are fully engaged from the stowed position (see assembly instructions, step 5)
- The mast is fully locked into position with mast engagement decals correctly aligned (see assembly instructions, step 4).
- The legs of the lift open and close satisfactorily.
- The red emergency stop button, located on the rear of the control box, is in the OFF (out) position.
- Push the up and down buttons on the hand control and confirm the boom rises and lowers.
- Fit the power pack to the lift and make sure the latch holding the pack in place is fully engaged. "Click" in place.

5. Safety Precautions

Please read and follow the safety precautions listed below. The operation and use of Oxford patient lifts is simple and straightforward. Following these few basic safety precautions will make lifting operations easy and trouble free.

READ AND UNDERSTAND THE USER INSTRUCTION MANUAL BEFORE USING YOUR “ADVANCE” LIFT

WARNING: Important safety information for hazards that might cause serious injury.

CAUTION: Information for preventing damage to the product.

NOTE: Information to which you should pay special attention.

WARNING

- **ALWAYS** plan your lifting operations before commencing.
- **ALWAYS** carry out the **DAILY CHECK LIST** (page 16) before using the lift.
- **ALWAYS** familiarise yourself with the operating control and safety features of a lift before lifting a patient.
- **DO NOT** use a sling unless it is recommended for use with the lift.
- **ALWAYS** check the sling is suitable for the particular patient and is of the correct size and capacity.
- **NEVER** use a sling, which is frayed or damaged.
- **ALWAYS** fit the sling according to the instructions provided (user instructions).
- **ALWAYS** check the safe working load of the lift is suitable for the weight of the patient.
- **ALWAYS** carry out lifting operations according to the instructions in the user manual.
- **NEVER** disconnect or bypass a control or safety feature because it seems easier to operate the lift.
- **DO NOT** lift a patient with the castor brakes on. Always let the lift find the correct centre of gravity.
- **DO NOT** attempt to manoeuvre the lift by pushing on the mast, boom or patient.
- **ALWAYS** manoeuvre the lift with the handle provided.
- **ALWAYS** lower the patient to the lowest comfortable position before transfers.
- **DO NOT** push a loaded lift at speeds, which exceed a slow walking pace (3 Kilometers/hour 0.8 meters/second).
- **DO NOT** push the lift over uneven or rough ground. Particularly if loaded.
- **DO NOT** attempt to push/pull a loaded lift over a floor obstruction, which the castors are unable to ride over.
- **NEVER** force an operating/safety control. All controls are easy to use and do not require excessive force.
- The **MINIMUM** load required to manually lower the hoist using the mechanical emergency down function is 30 kg.
- **DO NOT** park a loaded lift on **ANY** sloping surface.
- **DO NOT** use electric lifts in a shower.

- **DO NOT** charge an electric lift in a bathroom or shower room.
- **DO NOT** lift a patient unless you are trained and competent to do so.
- **YOUR** lift is for patient lifting. **DO NOT** use it, or allow it to be used, for any other purpose.
- **DO NOT** bump the lift down steps, loaded or unloaded.
- **DO NOT** attempt to negotiate a loaded lift on a slope, which exceeds 1:12 (approximately 5 degrees).
- **DO NOT** attempt to negotiate a slope without a second helper being present.
- **ALWAYS** check the hoist is not charging before moving as the electrical connection may be damaged.

6. Smart Monitor & Handset

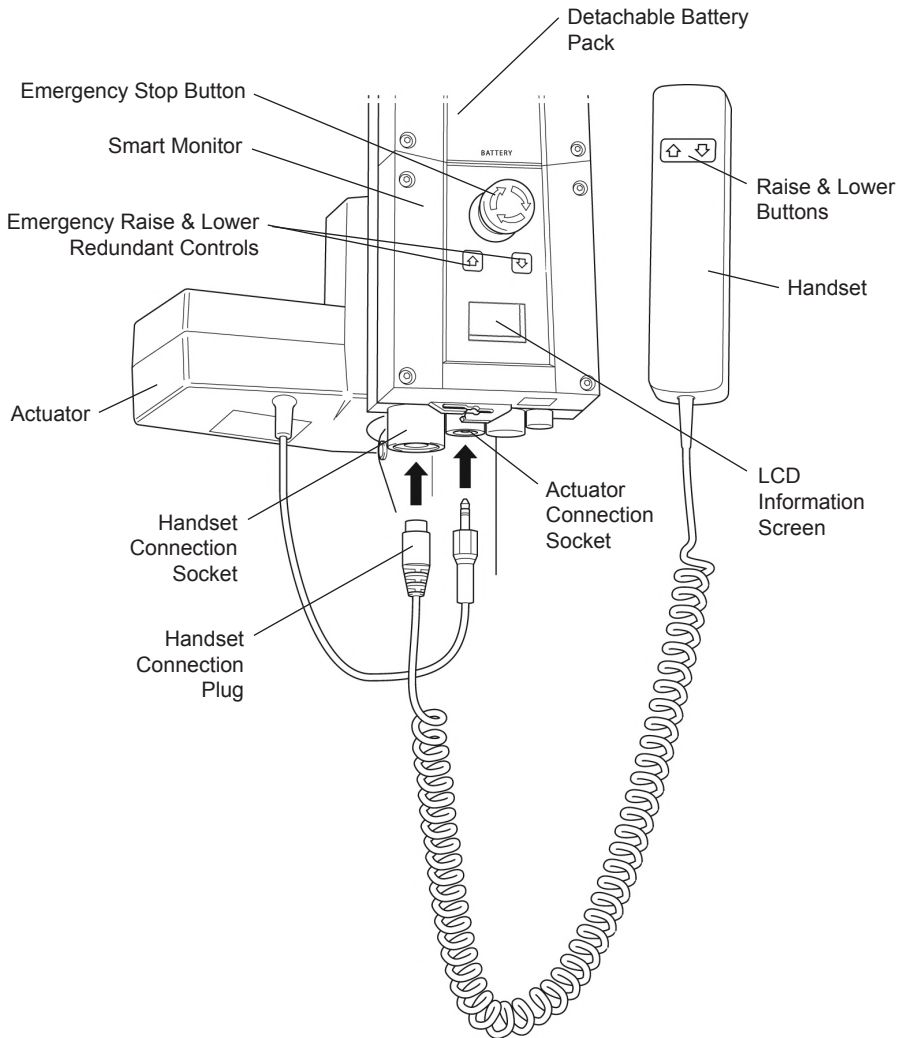

Intended Use

The Oxford Smart Monitor is a control system for Oxford Hoists. The Smart Monitor stores useful servicing information about the hoist that can be recalled when required. This servicing information includes:

- Number of patient lift cycles
- Total work done by actuator
- Number of lift overloads (attempted lifts above the safe working load)
- Number of days since last service interval

The Oxford Smart Monitor contains a microprocessor inside making it possible to read out service data via the on-board LCD screen.

Features

- Data collection in the control box with data display via LCD screen
- Work counter
- Intelligent cycle counter
- Service indicator
- Service interval indicator
- Overload information
- 3 step battery indicator



Benefits

- Improved safety for both patient and carer
- Accurate service data available at the touch of a button
- Optimised product life time
- Ease of maintenance for engineers and service technicians
- Fast and easy error identification

LCD Display Screen

The Oxford Smart Monitor has the option to read out information via the LCD display screen. It is possible to read out total lifting cycles, total work done, overloads and number of days since last service, which can be used to quickly and easily evaluate the condition of the lift actuator.

This information is accessed by a ½ second press on the 'UP' button on the User handset or redundant 'UP' button on the Smart Monitor.

	12034	Total Lifting Cycles
A*S	1257000	Total Work Done (Amps * Seconds)
	7	Number of Overloads
	90/180	Number of Days (since last service) / Number of Days (between services)

Service & Usage Information



When it is time for a service, the service symbol will appear on the display. In addition, when the user handset is activated, the Smart Monitor will give an audible signal giving notice to users that a service is required.

The service symbol will be displayed each time the raise or lower keys are depressed on the User handset. When the service symbol is displayed, contact your authorised service provider immediately to arrange a service.

You may continue to use your lift for a short period of time until a service has been carried out.



If the lift stops because of an overload (an attempt to lift more than the safe working load) the overload symbol will appear on the LCD display and the lift will cease to operate until the additional load (above the SWL) has been removed.

WARNING

If the LCD display screen on your Smart Monitor has recorded an overload, Joerns Healthcare recommend that ALL routine daily checks are carried out on the lift prior to further use (for a list of daily checks, please refer to your lift user manual). Joerns Healthcare also recommend that you contact your authorised Oxford service provider for additional guidance.

On-Board Redundant Controls

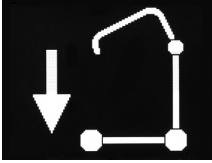

On-board redundant controls enable the lift to be raised or lowered in the event of an emergency.

Battery Information



The display showing full battery means that the battery is fully charged and the lift is ready for use.

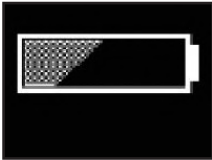

The display showing a half empty battery indicates that it is time to charge the battery.

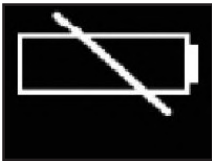

The empty battery symbol showing on the display indicates that the battery has no capacity left and should be placed on charge immediately.

WARNING

To avoid possible permanent damage to the battery, the battery should be placed on charge as soon as the display indicates the half empty battery symbol.

7. Operating Instructions

1. Leg adjustment

The legs on the Oxford Advance are adjustable for width. The legs can be opened to enable access around armchairs or wheelchairs. For transferring and negotiating narrow doorways and passages the lift legs should be in the closed position.

To achieve the adjustment, the leg adjuster pedal, located at the rear of the base, is compressed right (DOWN) to open the legs outwards and left (UP) to close the legs. The adjustment can be carried out with the patient in the lift, but whether loaded or unloaded the adjustment should be made when the lift is moving.

WARNING

Never lift with the legs in the closed/transport position. The closed position is for storage and transport only.

2. Castors and braking

The lift has two braked castors, which can be applied for parking. When lifting, the castors should be left free and un-braked, so that the lift will then be able to move to the centre of gravity of the lift. DO NOT apply the brakes because if the brakes are applied the patient might swing to the centre of gravity and this may prove disconcerting and uncomfortable.

3. Raising and lowering the boom

The movement of the boom is achieved by a powerful electric actuator, which is controlled by a simple hand control unit. The hand control has two buttons with directional arrows UP and DOWN. The actuator stops automatically at the limit of travel in both directions. The hand control plugs into a socket at the base of the control box. There is a hook on the rear of the hand control, which allows it to be “parked” on the mast or boom when not in use.

4. Emergency stop

The red Emergency Stop Button is located on the rear of the control box and is activated by pressing in. This will cut all power to the lift and only be reset by twisting the button counterclockwise and releasing.

5. Redundant controls

All Oxford lifts are fitted with raise and lower buttons on the control box. These are located underneath the emergency stop button and can be used to lower/raise the patient should the hand control fail.

6. Mechanical Emergency Down

In the case of a complete electrical failure the electric actuator is fitted with mechanical lowering device (RED BOSS). This will only operate when the lift is under load. The device must be pulled upwards to activate and a slow decent will commence.

Note: The MINIMUM load required to manually lower the hoist using the mechanical emergency down function is 30 kg.

7. Batteries

The batteries are protected from deep discharge by a LOW VOLTAGE ALARM. This will sound when the batteries need recharging and the hand control is being operated. It will not sound independently of the hand control being operated. CAUTION: DO NOT IGNORE THIS WARNING ALARM. Complete the lifting operation and place the lift on charge (see charging instructions).

WARNING

To avoid possible permanent damage to the battery, the battery should be placed on charge as soon as the display indicates the half empty battery symbol.

8. Slings

The selected sling is attached to the spreader bar hooks, each sling is supplied with instructions. Please study the instruction guide for the lifter and sling before using. Once the correct sling has been selected for the patient, attach it to the spreader bar hooks.

NOTE: For detailed fitting instructions, please refer to the user guide supplied with each sling.

WARNING

Joerns Healthcare recommends slings are checked regularly and before use for fraying or damage. DO NOT use slings that are worn or damaged.

WARNING

OXFORD RECOMMENDS THE USE OF GENUINE OXFORD PARTS. Oxford sling and lift products are designed to be compatible with one another. For country specific guidance on sling use and compatibility, please refer to the sling label or contact your local market distributor or Joerns Healthcare.

WARNING

Refer to maximum weight capacity of lift. Sling capacity is limited by the maximum capacity of the lift.

Charging Instructions

When the power pack needs charging it is removed from the lift and fitted to an off board charging unit.

Joerns Healthcare recommend an additional battery pack is purchased, so that one pack can be on charge at all times.

1. Remove the power pack from the lift. The pack is retained by a simple latch at the top of the power pack. Lift the latch and the power pack will be released.
2. Fit the power pack to the charging unit. The location and latching of the power pack to the charger is the same system as used on the lift.
3. Plug the charger mains plug into a suitable mains outlet and switch the mains supply ON.
4. Charging is automatic and will fully charge the batteries over a period of four (4) hours.

Note: Even if the charger is left plugged in for extended periods it will not allow the batteries to overcharge.

- a) Green Light - Indicates main power is on.
- b) Yellow Light - Indicates battery is charging.
- c) Battery will be fully charged when yellow light goes off.

Note: It is recommended that the battery be charged immediately upon receipt.

5. To return the lift to service, switch OFF the mains supply and remove the power pack from the charger. Fit the power pack to the lift and make sure the latch holding the pack in place is fully engaged. "Click" in place. The charging of Oxford electric lifts is simple and straightforward, but it is important to follow the charging instructions closely. Please pay particular attention to the following points, they will help you avoid problems with discharged batteries.

WARNING

- **The battery, charger, hand control and control box are NOT to be opened by unauthorised personnel. (Contact your distributor for warranty and repairs).**
- **DO NOT touch battery/charger terminals.**
- **KEEP the batteries fully charged. Place the battery on charge whenever it is not in use. If it is more convenient to do so, place on charge every night. The charger will not allow the batteries to overcharge.**
- **NEVER run the batteries completely flat. As soon as the audible warning sounds, complete the lifting operation in hand and place on charge.**
- **To avoid possible permanent damage to the battery, the battery should be placed on charge as soon as the display indicates the half empty battery symbol.**
- **NEVER store the battery for long periods without regular charging throughout the storage period.**
- **ALWAYS make sure the mains power to the charger is switched off before connecting or disconnecting the battery pack.**
- **NEVER leave the battery pack connected with the charger mains power switched off.**
- **DO NOT leave the charger switched on with the battery disconnected.**

- **DO NOT** use the lift while charging is taking place.
- **CHECK** the lift is not charging before moving as the electrical connection may be damaged.
- **NEVER** disconnect the charger plug by pulling on the cable.
- **BE CAREFUL** not to trip over the charge lead.
- **DO NOT** charge an electric lift in a bathroom or shower room.

8. Maintenance Schedule

All Oxford products are designed for minimum maintenance, however some safety checks and procedures are required. A schedule of DAILY tasks is detailed below. A list of replacement parts is available upon request.

DAILY CHECK LIST

Joerns Healthcare strongly recommends the following checks be carried out on a daily basis and before using lift.

- MAKE sure the lift moves freely on its castors.
- MAKE sure the spreader bar is free to rotate and swing. Check the spreader bar is firmly attached to the boom.
- ENSURE the mast is fully engaged into the mast slot and the mast locking device is securely tightened.
- EXAMINE the sling hooks on the spreader bar and side suspenders for excessive wear. If in doubt - do not use.
- EXAMINE slings for fraying or other damage. DO NOT use any sling if damaged or if the sling shows signs of wear.
- MAKE sure the legs open and close correctly.
- OPERATE the hand control to confirm the boom raises and lowers satisfactorily.
- CONFIRM the lift is not giving a low battery alarm when the hand control is operated. If the alarm sounds DO NOT use and place on charge immediately.
- ON electric powered lifts check the operation of the emergency stop button.

MAINTENANCE, INSPECTION AND TEST

Joerns Healthcare recommends a thorough inspection and test of the Oxford Advance lift and lifting accessories; slings, etc. are carried out on a regular basis. Inspection frequency varies depending on locality, so you must check with your dealer or local government agency as appropriate regarding how often an inspection is required. The examination and test should be conducted according to the recommendations and procedures provided in this manual. Whenever possible Joerns Healthcare recommends maintenance, inspection and certified testing is carried out by authorised service agent / dealers only.

NOTE: These recommendations are in compliance with the requirements of 1998 No2307 Health and Safety: The Lifting Operations and Lifting Equipment Regulations 1998. This is a UK regulation. Outside the UK please check your local country requirements.

***THESE CHECKS SHOULD INCLUDE:**

	Initially	Before Use	Service Intervals
1. SPREADER BAR: Check the spreader bar for freedom of rotation and swing. Check for wear on the central pivot. Check for firm attachment to the boom.	✓	✓	✓
2. BOOM: Check the attachment of the boom to the mast. Make sure there is only minimal side movement of the boom and the boom is free to rotate on the boom bearing.	✓	✓	✓
3. MAST: Check the operation of the mast-locking device. Make sure the mast fully engages into the socket. Check the bottom actuator mounting.	✓	✓	✓
4. ACTUATOR: The actuator should require no maintenance other than checking for correct operation and listening for unusual noise.			✓
5. SMART MONITOR: Check the function of the emergency stop button. Inspect the hand control socket for correct fitting. Check functioning of the hand control. Check the redundant controls and confirm they operate as intended. The MINIMUM load required to manually lower the hoist using the emergency lower function is 30 kg.	✓	✓	✓
6. BATTERIES: The batteries are housed in the power pack and should not require maintenance other than the regular charging as detailed in the charging instructions. Check that the connections remain clean.			✓
7. LEG ADJUSTMENT: Check the legs operate in both full extensions (inward/outward).	✓	✓	✓
8. CASTORS: Check all castors for firm attachment to the legs. Check for free rotation of the castor and the wheels.	✓	✓	✓
9. CLEANING: Clean with ordinary soap and water and/or any hard surface disinfectant. Harsh chemical cleaners or abrasives should be avoided as these may damage the surface finish of the lift. Avoid wetting any of the electrical parts.		✓	✓
10. LOAD TEST: The load test should be carried out in accordance with the manufacturer's test procedures.			✓
11. BASE AND WHEELS: Ensure base is even and level (all four wheels are on the floor).	✓	✓	✓
12. SLINGS: Check for wear and fraying.	✓	✓	✓
13. LUBRICATION: Oil pivot joints, including mast and boom connections, pedal assembly, spreader bar joint (only if required).			✓
14. FIXINGS: Check all nuts, bolts, screws and fasteners for excessive wear and for tightness. Replace as required.			✓

9. Technical Specifications

Specification

Safe Working Load.....	341 lbs.....	155Kgs
Maximum Overall Length.....	51 inches.....	1300mm
Minimum Overall Length.....	49 inches.....	1250mm
Maximum Overall Height.....	73 inches.....	1860mm
Minimum Overall Height.....	53.5 inches.....	1360mm

Folded Dimensions

Height.....	17.1 inches.....	450mm
Depth.....	46.4 inches.....	1180mm
Width.....	21.6 inches.....	550mm

Spreader Bar Max. Height.....	66.5 inches.....	1690mm
Spreader Bar Min. Height (usable).....	15.3 inches.....	390mm
Height at Maximum Reach.....	46 inches.....	1170mm
Reach at Maximum Height.....	25.6 inches.....	650mm
Reach at Minimum Height.....	13.7 inches.....	350mm
Maximum Reach*.....	32.8 inches.....	835mm
Turning Radius.....	55.9 inches.....	1420mm
Legs Open - External Width.....	42.5 inches.....	1080mm
Legs Open - Internal Width.....	39.3 inches.....	1000mm
Legs Closed - External Width.....	26.3 inches.....	670mm
Legs Closed - Internal Width.....	22.4 inches.....	570mm
Overall Height of Legs.....	4.5 inches.....	115mm
Ground Clearance.....	1.1 inches.....	30mm
Front Twin Castors.....	3.0 inches.....	75mm
Rear Braked Castors.....	3.9 inches.....	100mm

*Reach = centre of spreader bar to the front of the mast

Weights

Mast, Base & Boom Assembly.....	63.1 lbs.....	28.9kgs
Power Pack.....	6.2 lbs.....	2.8kgs
Total.....	69.9 lbs.....	31.7kgs
Base Assembly (not incl. battery).....	32.8 lbs.....	14.9kgs
Mast & Boom (not incl. battery).....	30.9 lbs.....	14.0kgs

All measurements are within a +5/-5 degree of tolerance.

ELECTRICAL SPECIFICATIONS:

BATTERIES.....	24 volt Rechargeable sealed lead acid type
BATTERY CAPACITY	3.2 Ampere hours
CHARGER RATED INPUT	100 - 240 V AC/ 50/60 Hz
CHARGER RATED OUTPUT	29.5 VDC, Max. 19 W

ELECTRIC SHOCK PROTECTION

CHARGER.....	CLASS II (EN 60601-1)
LIFT	INTERNAL POWER SOURCE

DEGREE OF SHOCK PROTECTION

CHARGER.....	TYPE B (EN 60601-1)
LIFT	TYPE B (EN 60601-1)

ENVIRONMENTAL CONDITIONS:

Outside this environment functionality and safety may be compromised.

OPERATING:

TEMPERATURE	5°C to 40°C
RELATIVE HUMIDITY	20% to 90% @ 30°C - not condensing
ATMOSPHERIC PRESSURE	700 to 1060 hPa

STORAGE:

TEMPERATURE.....	-10°C to +50°C
RELATIVE HUMIDITY	20% to 90% @ 30°C - not condensing
ATMOSPHERIC PRESSURE	700 to 1060 hPa

IP RATINGS

CONTROL BOX	IPX4
ACTUATOR.....	IPX4
OFF BOARD CHARGER	IPX5
BATTERY	IPX5
HANDSET	IPX5

DUTY CYCLES

ACTUATOR.....	10% (2 min./18 min.)
CHARGER.....	Approx. 4 hrs.

ACOUSTICS

A-Weighted sound power level	60 dB (A)
------------------------------------	-----------

KEY SYMBOLS:

The following symbols are used on the charger, control unit and battery:



Type B equipment, as per EN 60601-1



Class 2 equipment



The disposal of the charging and control unit should not be mixed with general household waste.

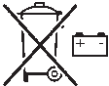

The disposal of batteries should not be mixed with general household waste.



The disposal of electronics should not be mixed with general household waste.



For indoor use



ATTENTION, consult accompanying documents.

WEEE Producers registration number WEE/GG0464RZ

10. Warranty

Joerns Healthcare has an established network of authorised distributors and service agents who will be pleased to handle all of your purchasing, warranty, repair and maintenance enquiries. It is recommended that our products are commissioned by your authorised distributor or service agent.

The distributor or service agent operates the warranty programme, so it is important to keep a record of their name, address and telephone number so they can be contacted should any problem arise. If you are in any doubt as to where your lift was purchased, Joerns Healthcare can trace the supplier if you quote the serial number of the lift.

All warranty claims are subject to the correct use and maintenance in accordance with the user instruction manual provided with each lift. Damage caused by use in unsuitable environmental conditions or failure to maintain the product in accordance with user and service instructions is not covered. Your statutory rights remain unaffected.

REMEMBER: Contact your authorised distributor or service agent for purchases, repairs, servicing and certified maintenance.

Your distributor:

Distributor

EVOCARE AUSTRALIA PTY LIMITED

A.B.N. 98 078 566 604

Trading as **EVOCARE** and **L&M EQUIPMENT**

P.O. Box 1144, Stafford Qld. 4053

Ph: 07 3355 8000 Fax: 07 3355 5043

Website: <http://www.evocare.com.au>

Email: sales@evocare.com.au

workshop@evocare.com.au

warehouse@evocare.com.au

accounts@evocare.com.au

